

# User Guide

## Elcometer 138

Abrasive Soluble Salt  
Test Kit - ASTM D4940

## CONTENTS

---

Section	Page
1 Overview	en-2
2 Box Contents	en-2
3 Test Procedure: ASTM D4940	en-3
4 Spares & Accessories	en-5
Appendix A: The Elcometer 138 Conductivity Meter	en-6

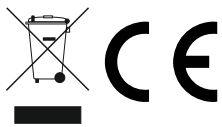

For the avoidance of doubt, please refer to the original English language version.

Kit Dimensions: 456 x 384 x 127mm (18 x 15.1 x 5")

Kit Weight: 2.2kg (4lb 14oz)

A Material Safety Data Sheet for the Elcometer 138 Standard 1413µS/cm Calibration Solution is available to download via our website:

[http://www.elcometer.com/images/stories/MSDS/Elcometer\\_138\\_1413uScm\\_Calibration\\_Solution.pdf](http://www.elcometer.com/images/stories/MSDS/Elcometer_138_1413uScm_Calibration_Solution.pdf)

### CAUTION



If the standard solution used for calibration of the meter comes into contact with the skin, wash the skin with fresh water. If the standard solution comes into contact with eyes, immediately flush the eye with large amounts of fresh water and seek medical advice.

© Elcometer Limited 2020. All rights reserved. No part of this document may be reproduced, transmitted, transcribed, stored (in a retrieval system or otherwise) or translated into any language, in any form or by any means (electronic, mechanical, magnetic, optical, manual or otherwise) without the prior written permission of Elcometer Limited.

## 1 OVERVIEW

---

Abrasives used for blast cleaning surfaces can be contaminated with soluble salts due to the source or the re-use of the blasting media.

This contamination can be transferred to the blast cleaned surface and result in accelerated corrosion conditions and also cause premature coating failure, if this contamination is not removed prior to applying the coating.

Testing abrasives for soluble salt contamination can be carried out quickly and easily using the Elcometer 138 Abrasive Soluble Salt Test Kit, according to the ASTM D4940 method.

Elcometer 138 Abrasive Soluble Salt Test Kit provides all the equipment needed to carry out the test in the field or in the laboratory.

## 2 BOX CONTENTS

---

- Elcometer 138 Conductivity Meter<sup>a</sup>
- Calibration Solution 1413 $\mu$ S/cm; 14ml (0.47 fl oz)
- Conditioning Solution; 14ml (0.47 fl oz)
- Bottle of Pure Water; 1000ml (33.8 fl oz)
- Glass Beaker; 100ml (3.4 fl oz)
- Glass Beaker; 600ml (20.3 fl oz)
- Plastic Measuring Beaker; 500ml (16.9 fl oz)
- Funnel
- Stirring Rod
- Filter Papers; Box of 100
- CR2032 Lithium Batteries; x2 (supplied fitted to the Elcometer 138)
- Transit Case
- User Guide

<sup>a</sup> The Elcometer 138 Conductivity Meter included in the test kit measures the conductivity of aqueous solutions. The meter is NOT designed to measure solids, organic solvents, surfactant, oil, adhesive, alcohol, strong acids (pH: 0 to 2) or strong alkalis (pH: 12 to 14). The life of the sensor will be extremely short if these substances are measured.

### 3 TEST PROCEDURE: ASTM D4940

---

#### 3.1 BEFORE YOU START

- 1 Calibrate the conductivity meter, see Appendix A, Section A2.5 on page en-11.
- 2 Determine the conductivity meter sensor cell constant, see Section 3.2 below.
- 3 Rinse the beakers, stirring rod and funnel with pure water until tests show the rinse water has a conductivity of 5µS/cm or less.
  - ▶ Measure the conductivity of the rinse water using the Elcometer 138 Conductivity Meter, see Appendix A, Section A2.6 on page en-12.
- 4 As the test is sensitive, we recommend that clean latex or nitrile gloves are worn during the test procedure to prevent cross contamination.

#### 3.2 DETERMINING THE SENSOR CELL CONSTANT ( $K_{25}$ )

The conductivity meter sensor cell constant should be determined and checked periodically using the procedure outlined below.

The Elcometer 138 Conductivity Meter and standard 1413 µS/cm (1.413 mS/cm) calibration solution<sup>b</sup> supplied in the kit can be used for this purpose.

- 1 Using the Elcometer 138 Conductivity Meter, measure the conductivity of the standard calibration solution at 25°C (77°F), see Appendix A, Section A2.6 on page en-12.
  - ▶ Rinse the sensor cell several times with the solution to be measured before taking the reading.
- 2 Calculate the sensor cell constant ( $K_{25}$ ) using the following formula:

$$K_{25} = (C_s / C_m)$$

where:

- $K_{25}$  = conductivity sensor cell constant
- $C_m$  = measured conductivity of the standard calibration solution
- $C_s$  = specific conductivity of the standard calibration solution (1413 µS/cm if using the standard calibration solution supplied.)

*Note: Users can prepare their own potassium chloride solution instead of using the standard calibration solution supplied. Refer to the ASTM Standard for further information.*

<sup>b</sup> Additional bottles of calibration solution are available to purchase from Elcometer or your local Elcometer supplier, see Section 4 'Spares & Accessories' on page en-5.

### 3 TEST PROCEDURE: ASTM D4940 (continued)

#### 3.3 TEST PROCEDURE

- 1 Measure out 300ml of abrasive in the 600ml glass beaker then add 300ml of pure water.
- 2 Stir the solution for one minute using the stirring rod. Leave to stand for 8 minutes, then stir again for a further one minute.
- 3 Insert a filter paper into the funnel and filter a sufficient amount of the solution into the 100ml glass beaker, discarding the first 10ml of filtrate.
- 4 Rinse the Elcometer 138 Conductivity Meter sensor cell with pure water until tests show the rinse water has a conductivity of  $5\mu\text{S}/\text{cm}$  or less, see Appendix A, Section A2.6 on page en-12.
- 5 Measure the conductivity of the solution using the Elcometer 138 Conductivity Meter, see Appendix A, Section A2.6 on page en-12.
  - ▶ Rinse the sensor cell several times with the solution to be measured before taking the reading.
- 6 Measure the conductivity of successive portions of the solution until a constant value is obtained.

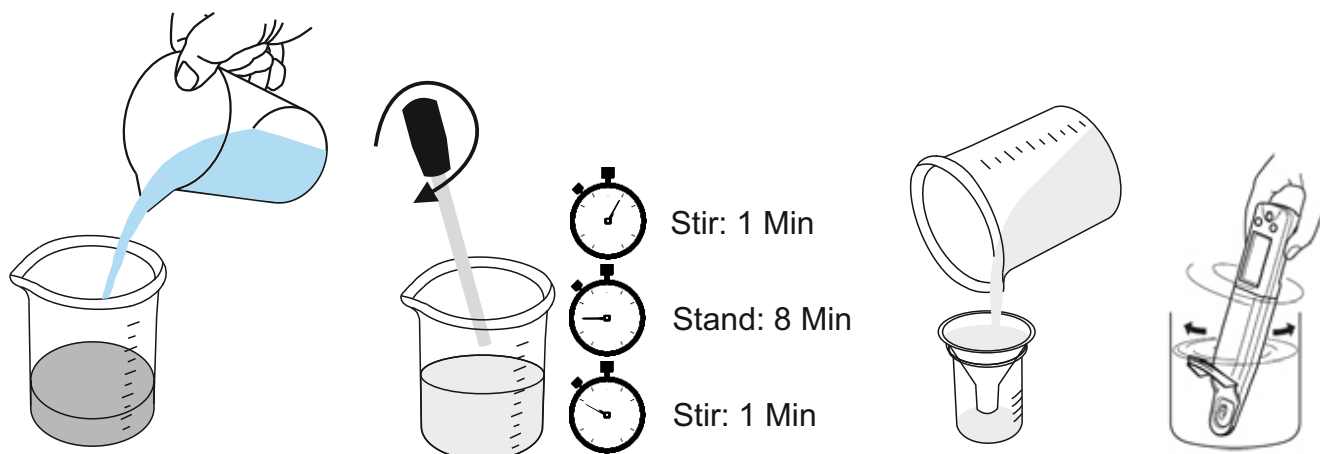

#### 3.4 CALCULATE THE CONDUCTIVITY OF THE ABRASIVE ( $C_s$ )

Calculate the specific conductivity of the abrasive ( $C_s$ ) using the following formula:

$$C_s = C_m \times K_{25}$$

where:

$C_s$  = specific conductivity of the abrasive

$C_m$  = measured conductivity of abrasive / pure water solution

$K_{25}$  = conductivity cell constant, see Section 3.2 on page en-3.

#### 3.5 AFTER TEST

Rinse all components of the test kit in pure water. They can then be re-used.

## 4 SPARES & ACCESSORIES

---

The Elcometer 138 Abrasive Soluble Salt Test Kit is complete with all the items required to get started and take measurements however, over the life of the kit, replacements may be required. The following items are available from Elcometer or your local Elcometer supplier.

<b>Description</b>	<b>Part Number</b>
Elcometer 138 Conductivity Meter	E138-CM
Replacement Sensor for Conductivity Meter	T13830628
Standard 1413 $\mu$ S/cm Calibration Solution; 250ml (8.45fl oz) Bottle	T13830629-2
Bottle of Pure Water; 1000ml (33.8 fl oz)	T13827494
Glass Beaker; 100ml (3.4 fl oz)	T13827495
Glass Beaker; 600ml (20.3 fl oz)	T13827496
Plastic Measuring Beaker; 500ml (16.9 fl oz)	T13827498
Funnel	T13827497
Stirring Rod	T13827499
Filter Papers; Box of 100	T13827500

A Material Safety Data Sheet for the Elcometer 138 Standard 1413 $\mu$ S/cm Calibration Solution is available to download via our website:

[http://www.elcometer.com/images/stories/MSDS/Elcometer\\_138\\_1413uScm\\_Calibration\\_Solution.pdf](http://www.elcometer.com/images/stories/MSDS/Elcometer_138_1413uScm_Calibration_Solution.pdf)

### CAUTION



If the standard solution used for calibration of the meter comes into contact with the skin, wash the skin with fresh water. If the standard solution comes into contact with eyes, immediately flush the eye with large amounts of fresh water and seek medical advice.

# Appendix A

## Elcometer 138

### Conductivity Meter

<b>Section</b>	<b>Page</b>
A1 The Controls & Display	en-7
A2 Using the Elcometer 138	en-8
A3 Care & Maintenance	en-13
A4 Warranty Statement	en-13
A5 Technical Specification	en-14
A6 Spares & Accessories	en-14
A7 Legal Notices & Regulatory Information	en-15

## A1: THE CONTROLS & DISPLAY

The Elcometer 138 Conductivity Meter is operated using 3 buttons and displays readings and other information on the LCD screen.

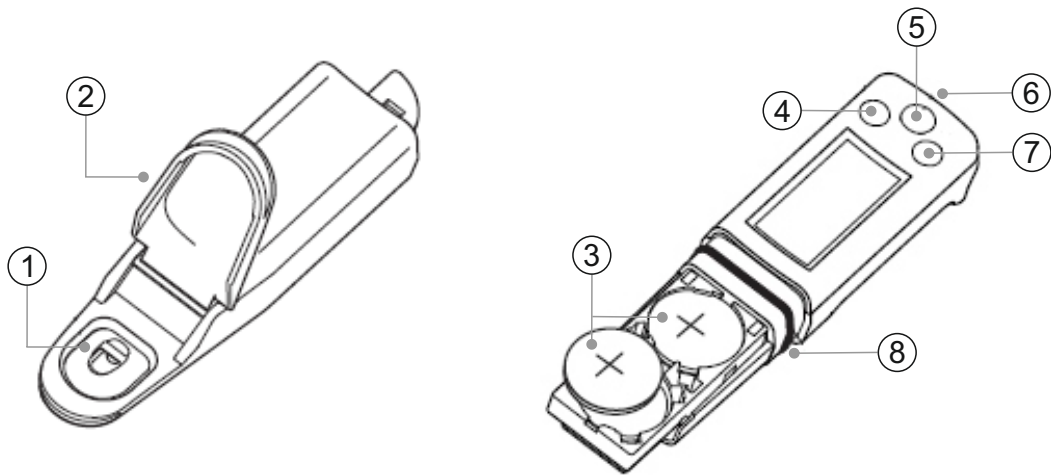

ELCOMETER 138 CONDUCTIVITY METER OVERVIEW		
1	Measurement Cell	Place a liquid sample in this cell to measure it with the electrode located on the bottom of the cell.
2	Protection Cover	Protects the measurement cell and flat sensor in storage.
3	Lithium Batteries	CR2032 x 2
4	MEAS Button	Sets the measurement mode (EC). View the ambient temperature measured with the internal temperature sensor (to be used as a guide only). Switches from calibration mode to measurement mode.
5	ON/OFF Button	Turns the meter On / Off.
6	Strap Eyelet	A strap can be attached here.
7	CAL Button	Starts calibration procedure.
8	Waterproof Gasket	Makes the meter waterproof.



## A1: THE CONTROLS & DISPLAY (continued)

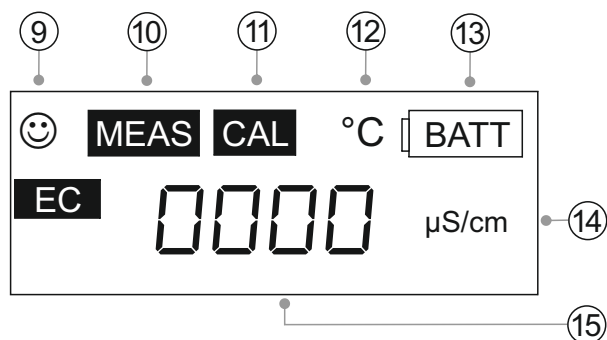

DISPLAY INDICATORS		
9	Stability Icon	Illuminates when measured value is stabilised.
10	MEAS Icon	Illuminates when in measurement mode.
11	CAL Icon	Flashes during calibration and illuminates steadily when calibration is finished.
12	Temperature Alarm Icon	Flashes when the ambient temperature does not meet the specified operating temperature of 5°C to 40°C (41°F to 105°F).
13	Battery Alarm Icon	Illuminates when the batteries are low and need to be replaced.
14	Measurement Units	The default setting is μS/cm
15	Measured Value	Displays the measured conductivity of the sample

## A2 USING THE ELCOMETER 138

### A2.1 CAUTION

- The sensor is a consumable part. If it becomes damaged or its performance deteriorates, it will need to be replaced - see Section A6 'Spares & Accessories' on page en-14.
- Do not drop the meter.
- Never apply undue force when opening the meter (to change the batteries or sensor).
- Do not exert undue force on the sensor.
- Do not allow utensils (tweezers, pipette, etc) to touch sensor cell.
- Do not measure samples hotter than 40°C (105°F).
- Do not allow contact with solvents.

## A2: USING THE ELCOMETER 138 (continued)

- Do not subject the meter to high temperature or humidity.
- Although the product is waterproof, avoid immersing it completely. If the meter is accidentally dropped in water, take it out and remove the moisture.
- To ensure the meter is waterproof check that the waterproof gasket is clean, not damaged, Seated properly in the groove and is not twisted or warped.

### A2.2 FITTING AND REPLACING THE BATTERIES

The Elcometer 138 Conductivity Meter uses dry cell batteries only and is supplied with two CR2032 lithium batteries fitted with an isolation strip. Remove the isolation strip before first use.

#### To fit or replace the batteries:

- 1 Place batteries in the battery clips ensuring correct polarity.
- 2 To reassemble the meter, slide the sensor onto the body of the meter and push the body and sensor together gently until sensor retaining clip engages.

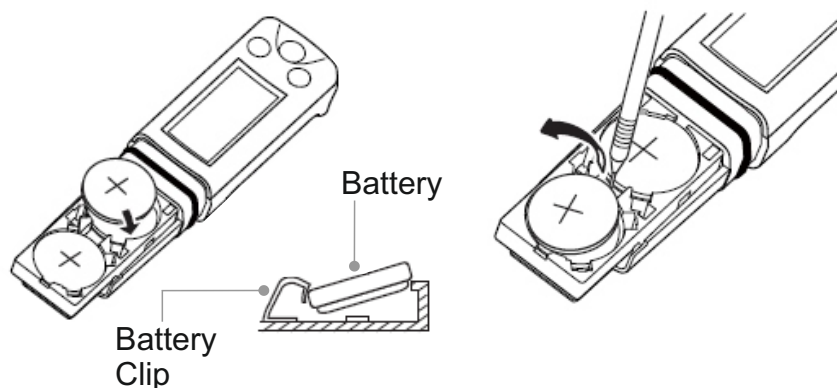

When the battery voltage becomes low, the low battery warning indicator will flash. Replace both batteries immediately.

*Note: Lithium batteries must be disposed of carefully to avoid environmental contamination. Please consult your local Environmental Authority for information on disposal in your region. **Do not dispose of any batteries in fire.***

## A2: USING THE ELCOMETER 138 (continued)

### A2.3 ATTACHING & DETACHING THE SENSOR

Ensure the meter is turned OFF before attaching / detaching the sensor. If the meter is turned ON with the sensor detached, the battery alarm may illuminate. In this case, turn the meter OFF and attach the sensor, and then turn the meter ON again.

#### Attaching the sensor:

- 1 Ensure that the waterproof gasket is clean and undamaged.
- 2 Slide the sensor across the meter so the clip (A) fits into the hole on the sensor tongue (a), as shown.

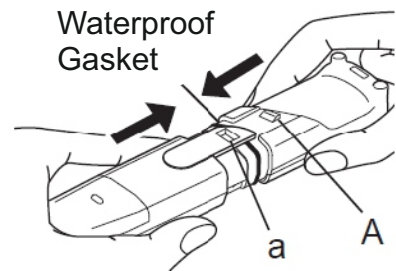

*Note: Ensure that the waterproof gasket is lying flat and not twisted.*

#### Detaching the sensor:

- 1 Lift the sensor tongue tip and slide the sensor slightly away from the meter.
- 2 The sensor can now be completely removed from the meter.

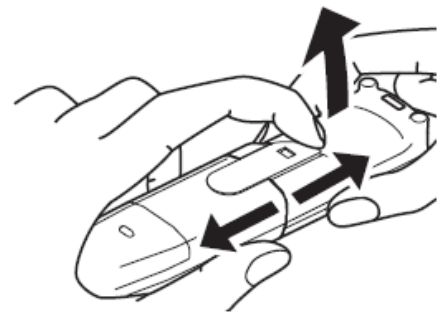

When removing the sensor, do not let any water penetrate the inside of the meter. If some moisture remains on the waterproof gasket, very carefully wipe the moisture off.

#### Correct procedure for closing meter after removal of the sensor:

Ensure that the sensor tongue is outside the meter case. If the tongue is inserted between the case and the connector of the meter, it may damage the connector.

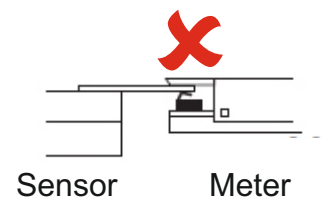
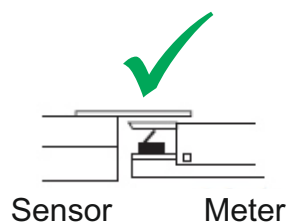
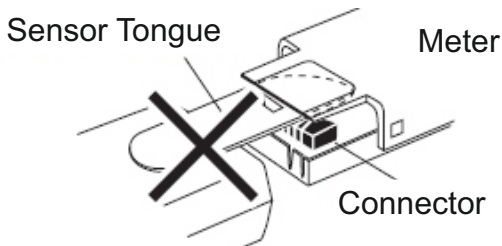

The sensor is a consumable part. If it becomes damaged or its performance deteriorates, it will need to be replaced, see Section A6 'Spares & Accessories' on page en-14.

## A2: USING THE ELCOMETER 138 (continued)

### A2.4 ELECTRODE SURFACE TREATMENT PROCEDURE

When using the sensor for the first time or again after several weeks of disuse, perform the electrode surface treatment procedure as follows:

- 1 Put some drops of the conditioning solution into the measurement cell.
- 2 Leave for approximately 10 minutes.
- 3 Clean the measurement cell with running water.
- 4 Wash the measurement cell with standard solution.
- 5 Perform the calibration procedure, see Section A2.5 below.

### A2.5 CALIBRATING THE ELCOMETER 138

When using the sensor for the first time or again after several weeks of disuse, perform the electrode surface treatment procedure, see Section A2.4 above, before calibrating the meter.

- 1 Press the ON/OFF button to switch the meter on.
- 2 Press the **CAL** button until **CAL** appears on the display.
- 3 Open the protection cover and place an appropriate amount of the standard 1413 $\mu$ S/cm solution supplied, see Section A6 'Spares & Accessories on page en-14, into the measurement cell avoiding the inclusion of bubbles. Washing the sensor with standard solution beforehand may provide more accurate calibration.
  - ▶ Bubbles in the solution may cause the measurement to be inaccurate.

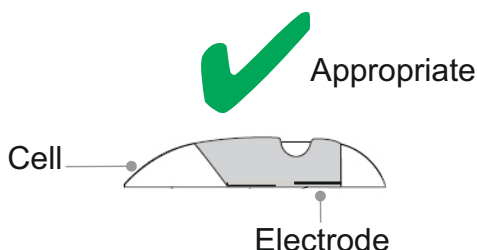
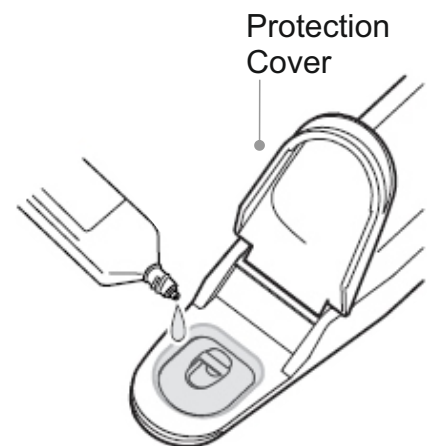

## A2: USING THE ELCOMETER 138 (continued)

- 4 Close the protection cover and press the **CAL** button for over 2 seconds. **CAL** and ☺ flash and the calibration value is displayed. After the calibration is completed, **CAL** and ☺ stop flashing and illuminate steadily.
  - ▶ If **CAL** continues to flash and the 'Err' (error message) is displayed, the calibration has failed. Check that the standard solution conductivity is correct and perform the calibration procedure again after thoroughly cleaning the sensor. If the calibration failed whilst using the correct standard solution, the sensor may be damaged and should be replaced, see Section A6 'Spares & Accessories' on page en-14.
- 5 Clean the sensor with tap water and remove moisture.
- 6 Press the **MEAS** button for 0.5 seconds to enter the measurement mode and prepare for measurement.

### A2.6 TAKING A READING

- 1 Press the ON/OFF button to switch the meter on
- 2 Open the protection cover.
- 3 Immerse the sensor into the sample and stir gently 2 or 3 times.
- 4 Read the value displayed when ☺ appears. ☺ illuminates when measured value is stabilised.

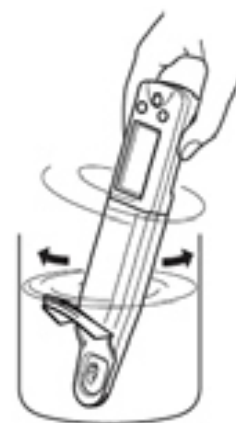

*Note: If a measurement result is out of the specified measurement range, the displayed measured value flashes.*

*Note: Although this product is waterproof, avoid immersing it completely. If the product is accidentally dropped into water, take it out of the water and remove the moisture from the instrument.*

### A2.7 AFTER MEASUREMENT

- 1 Press the ON/OFF button to switch the meter off.
- 2 Wash the sensor with tap water and wipe away any residual water using a clean tissue.
- 3 Replace the sensor protection cap.

*Note: If the meter is to remain unused for a long period of time, use pure water instead of tap water to wash the sensor.*

### **A3: CARE & MAINTENANCE**

---

The Elcometer 138 Conductivity Meter is designed to give many years reliable service under normal operating conditions.

- Prolonged periods of non-use may cause the sensor to dry out. This can result in malfunction or unstable readings. Pour conditioning solution into the sensor cell and leave for a few minutes to allow the sensor to become saturated. Wash the sensor with water prior to use.
- If the measuring surface of the sensor is contaminated or if air bubbles are regularly present in the sample, clean the sensor using a diluted neutral detergent (diluted 100 times).
- The Elcometer 138 Conductivity Meter incorporates a Liquid Crystal Display. If the display is heated above 50°C (120°F) it may be damaged. This can happen if the meter is left in a car parked in strong sunlight.

The Elcometer 138 Conductivity Meter does not contain any user-serviceable components. In the unlikely event of a fault, the meter should be returned to your local Elcometer supplier or directly to Elcometer Limited - contact details can be found on our website, [www.elcometer.com](http://www.elcometer.com). The warranty will be invalidated if the instrument has been opened.

### **A4: WARRANTY STATEMENT**

---

The Elcometer 138 Conductivity Meter is supplied with a 12 month warranty against manufacturing defects, excluding contamination and wear.

The conductivity meter sensor is supplied with a 3 month warranty against manufacturing defects, excluding contamination and wear.

**A5: TECHNICAL SPECIFICATION**

<b>Measurement Principle</b>	2 Electrode Bipolar AC
<b>Measurement Mode</b>	Conductivity, Temperature
<b>Minimum Sample Volume</b>	0.12ml
<b>Measurement Range</b>	0 - 19.99mS/cm
<b>Resolution</b>	0 - 1999 $\mu$ S/cm : 1 $\mu$ S/cm 2.00 - 19.99mS/cm : 0.01mS/cm
<b>Accuracy</b>	$\pm$ 2% of full scale (for each range)
<b>Operating Temperature</b>	5°C to 40°C (41°F to 105°F)
<b>Operating Humidity</b>	85% or less relative humidity (no condensation)
<b>Battery Type</b>	2 x CR2032 lithium
<b>Battery Life</b>	Approximately 200 hours continuous use without backlight
<b>Dimensions</b>	164 x 29 x 20mm (6.5 x 1.1 x 0.79")
<b>Weight</b>	50g (1.76 oz) - including sensor and batteries

**A6: SPARES & ACCESSORIES**

<b>Description</b>	<b>Part Number</b>
Standard 1413 $\mu$ S/cm Calibration Solution: 250ml (8.45fl oz) Bottle	T13830629-2
Replacement Sensor for Conductivity Meter	T13830628

A Material Safety Data Sheet for the Elcometer 138 Standard 1413 $\mu$ S/cm Calibration Solution is available to download via our website:  
[http://www.elcometer.com/images/stories/MSDS/Elcometer\\_138\\_1413uScm\\_Calibration\\_Solution.pdf](http://www.elcometer.com/images/stories/MSDS/Elcometer_138_1413uScm_Calibration_Solution.pdf)

**CAUTION**

If the standard solution used for calibration of the meter comes into contact with the skin, wash the skin with fresh water. If the standard solution comes into contact with eyes, immediately flush the eye with large amounts of fresh water and seek medical advice.

## A7: LEGAL NOTICES & REGULATORY INFORMATION

---

Declaration of Conformity: This product complies with the requirements of the following EU Directives:

2014/30/EU      Electromagnetic Compatibility

2011/65/EU      Restriction of the use of certain hazardous substances

The Declaration of Conformity is available to download via:

[www.elcometer.com/images/stories/PDFs/Datasheets/Declaration of Conformity/English/DoC\\_138.pdf](http://www.elcometer.com/images/stories/PDFs/Datasheets/Declaration%20of%20Conformity/English/DoC_138.pdf)

This product is Class B, Group 1 ISM equipment according to CISPR 11.

Class B product: Suitable for use in domestic establishments and in establishments directly connected to a low voltage power supply network which supplies buildings used for domestic purposes.

Group 1 ISM product: A product in which there is intentionally generated and/or used conductively coupled radio-frequency energy which is necessary for the internal functioning of the equipment itself.

elcometer® is a registered trademark of Elcometer Limited, Edge Lane, Manchester, M43 6BU.  
United Kingdom

All other trademarks acknowledged.

Please ensure that all packaging is disposed of in an environmentally sensitive manner. Consult your local Environmental Authority for further guidance.

